

## Spring-Clips SB-EF/E

Glueing methods are usually used to connect and secure the ferrite cores. Glues, such as Araldite, require the ferrite cores to be kept under constant pressure until the glue has hardened. A more advantageous and quicker method is by using stainless steel spring-clips SB. The holding pressure is almost constant over the whole operating temperature range.

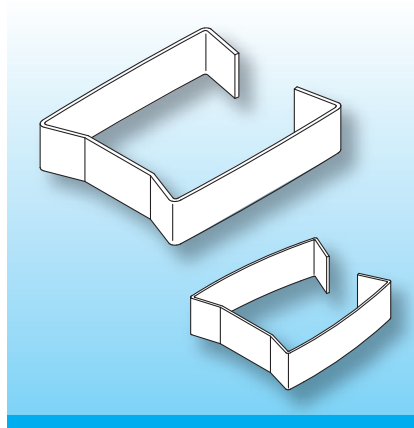

One clip is required to assemble a wound coilformer with one pair of ferrite cores.

The use of a drop of glue is recommended, to connect the ferrites to the coilformer and to prevent frequency noise.

Special materials/designs on request. Dimension in mm/inch.

When ordering please quote type and order-code.

Type	Order-Code		A	B	C	D	I
SB-EF 8/sa	N0133-085	on request	8.2 0.323	8.8 0.346	2.0 0.079	2.0 0.079	0.15 0.006
SB-EF 10/sa	N0134-085	on request	10.3 0.406	10.8 0.425	2.5 0.098	2.0 0.079	0.20 0.008
SB-EF 12,6/sa	78940-085		13.1 0.516	14.0 0.551	3.5 0.138	3.0 0.118	0.25 0.010
SB-EF 16/sa	78941-085		16.7 0.657	17.4 0.685	4.5 0.177	4.0 0.157	0.30 0.012
SB-EF/E 20/sa	78942-085		20.8 0.819	21.6 0.850	5.5 0.217	5.0 0.197	0.30 0.012
SB-EF 25/sa	78943-085		25.8 1.016	27.0 1.063	6.5 0.256	5.5 0.217	0.30 0.012
SB-EF 32/sa	78944-085		32.9 1.295	34.4 1.354	8.5 0.335	7.0 0.276	0.30 0.012
SB-E 30/sa	78947-085		30.8 1.213	32.2 1.268	6.5 0.256	6.0 0.236	0.30 0.012

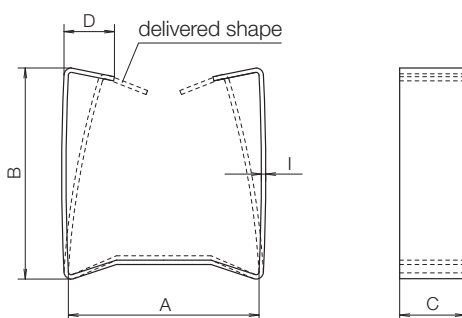

### © 01/2012 by NORWE GmbH

All dimensions in mm/inch

The permissible deviations according to DIN 16901 apply as tolerances

Warranties:  
refer to Terms and Conditions of Sale

### NORWE GmbH

Postfach 13 56  
51691 Bergneustadt  
Paulstraße 5, Pernze  
51702 Bergneustadt  
Deutschland  
Telefon +49 (0) 27 63-807-0  
Telefax +49 (0) 27 63-807-77  
E-mail verkauf@norwe.de  
Internet www.norwe.de  
www.norwe.eu

### NORWE Inc.

P.O. Box 25 11  
North Canton, OH 44720-0511  
United States of America  
Telefon +1-330 497-8113  
Telefax +1-330 305-0592  
E-mail usa@norwe.com  
Internet www.norwe.com